

Funktion One are English inventors and manufacturers of professional loudspeaker systems.

Achieving the best possible audio quality is the principle motivating factor at Funktion One. We are intent on sonic accuracy and our technological approach avoids the use of both system EQ (with its inherent phase and headroom problems) and compression driver mid-range (with its inherent harshness and distortion). Our loudspeaker systems also have excellent directional control allowing sound to be focused where it's needed and minimising out-of-venue environmental impact.

Our designs also focus on maximising efficiency (conversion of amplifier power into acoustic energy) as this tends to produce alive and responsive sound. It also means that less electrical power is required for a given acoustic output making F1 Resolution systems more energy efficient compared to alternatives.

We understand sound to be the most important of our senses and in fact, the root of the structure of the entire Universe. As such, we try to pay the amazing acuity of human hearing the respect it deserves by providing products that deliver as much resolution and detail as is possible. We also pay considerable attention to the emotional effect of not just music, but the sound itself, what you might call its 'quality'. In a world where everything is 'dumbing down' and finesse and subtlety are rapidly disappearing, it is a source of pride to us that we are continually going in the opposite direction, expanding the envelope. On a spiritual level, good music and good sound has the effect of opening peoples' minds and deepening their consciousness which can only be good for the planet.

Funktion One has also pioneered the Ambisonic surround Sound System for large-scale events and could claim to have more experience in the implementation of this exciting spatial technology than any other organization. This emerging technology has been used by the Chemical Brothers, Glastonbury Festival, London's Millennium Dome central show and more recently at The Glade Festival.

We hope that your visit to our website will prove both informative and enjoyable and that ultimately you will derive pleasure and success from working with our products.



**Funktion-One F118 MK2  
Single 18" Subwoofer**

The F118 Mk2 is the single 18" version of the F218 offering a more compact horn-loaded enclosure. In common with the F218, the Mark 2 version brings refined loading, improved heat dissipation and an updated driver specification. It provides strong, well-defined, clean bass from a small and manageable package. The F118 can be supplied with an optional pole mount for use with a wide range of mid-high products including the F101, F1201, F88, R1 and R2SH. An installation version of this enclosure with flying points is also available; which can be effectively used to provide bass extension to products such as the AX88.

Features:

- Proven loading design with latest Andrews' tuning
- New driver orientation provides improved cooling
- Powerful and compact
- Funktion One designed driver
- Integral handles
- Optional throat grill
- Optional wheels
- Optional pole mount (35mm diameter)



**Funktion-One Evo 7T  
Very High Intensity Touring  
Loudspeaker**

The Evolution 7T is a very high intensity touring loudspeaker and is incredibly compact for its output performance. The Evo 7T is fully horn-loaded with 15" mid-bass, 10" Funktion One signature mid-range and a 1.4" compression driver. The Evolution 7T has 40 degree nominal horizontal dispersion and physically arrays at 30 degrees, three wide giving smooth coverage to 100 degrees, suitable for crowd sizes of around 2,500 people.

Perfect for both Live and Dance use, Evo7T touring systems offer state-of-the-art Funktion One sound quality.

We recommend their use with Funktion One bass enclosures.

Features:

- Fully horn loaded for high efficiency
- Three-way
- Funktion One designed drivers
- Low weight Neodymium Magnets throughout
- Fully specified for Touring use with integrated flying system
- Optional Wheelboard (coming soon)
- Optional sturdy grille for discrete appearance



**Funktion-One Evo 7E**  
**Very High Intensity Loudspeaker**

The Evolution 7E is a very high intensity loudspeaker and is incredibly compact for its output performance. The Evo 7E is fully horn-loaded with 15" mid-bass, 10" Funktion One signature mid-range and a 1.4" compression driver. The Evolution 7E has 40 degree nominal horizontal dispersion and physically arrays at 30 degrees, three wide giving smooth coverage to 100 degrees, suitable for crowd sizes of around 2,500 people.

Perfect for both Live and Dance use, Evo7E systems offer state-of-the-art Funktion One sound quality.

We recommend their use with F121, F221 or BR221 bass enclosures.

Features:

- Fully horn loaded for high efficiency
- Three-way
- Funktion One designed drivers
- Low weight Neodymium Magnets throughout
- Fitted with M10 flypoints
- Optional Wheelboard (coming soon)
- Optional sturdy grille for discrete appearance
- Evo7EH and Evo7SH mid-high versions also available



**Funktion-One Evo 6E**  
**High Intensity Loudspeaker**  
**Enclosure**

The Evolution 6E is a high intensity loudspeaker combining horn-loaded 15" mid-bass, 10" Funktion One signature mid-range and a 1.4" compression driver into a very compact enclosure offering class leading efficiency and performance. The Evo 6E has 50° nominal horizontal dispersion and physically arrays at 40°, two wide giving smooth coverage over 90°.

Perfect for all applications and genres of music, Evolution 6E systems offer state-of-the-art Funktion One sound quality.

We recommend their use with F121, F221 or BR221 bass enclosures.

Features:

- Fully horn loaded for high efficiency
- Three-way
- Funktion One designed drivers
- Low weight Neodymium Magnets throughout
- Fitted with M10 flypoints
- Optional Wheelboard (coming soon)
- Optional sturdy grille for discrete appearance
- Evo6EH and Evo6SH mid-high versions also available



**Funktion-One Resolution 5  
Skeletal**

The Resolution 5S is a three-way, long throw loudspeaker enclosure designed to operate from 100Hz upwards. The unique and patented Axhead loading device not only gives incredible efficiency and dispersion control, but also increases high frequency output from the 8" cone driver. This means that the crossover point to the compression driver can be raised to an astonishing 6kHz for dramatically reduced distortion compared to compression driver based midrange systems so prevalent in the industry. It offers high intensity, controlled dispersion with sound quality equal to that of the enclosed versions. The Resolution 5S is suited to applications including demanding club and auditoria venues. The system delivers sound of unprecedented beauty, intelligibility and clarity and is highly efficient. For weight critical applications the system can be specified with lightweight Neodymium magnets.

**Features:**

- Lightweight minimalist design approach
- Minimal processing and no EQ required
- Equal sound quality to enclosed versions
- Controlled dispersion
- Funktion One designed drivers
- Optional lightweight Neodymium drivers
- Suspension points provided



**Funktion-One Resolution 5E**

The Resolution 5E presents a series of cost effective options for the installation and touring world alike, bridging the application gap between the Skeletal and Full Touring versions of the Resolution 5 in terms of enclosure design features. With equal sound quality to the full touring Resolution 5, the 5E is supplied in a simplified 'trapezoid' enclosure without the built in flying hardware provided on the full touring version. A dedicated (external sword type) flying system specific to the Resolution 5E will make this product a highly attractive choice in applications where rigging and derigging is infrequent. It is obviously also ideally suited to ground stacked use which is facilitated by a comprehensive stacking board system.

**Features:**

- Choice of Ceramic or Neodymium drivers
- Simplified enclosure ideal for ground stack touring or for permanent installations
- Same sonic performance as full touring version
- Dedicated installation flying hardware available if required
- Optional Wheelboard (as supplied with full touring version)
- Ground Stack Securing system available
- Optional scrim for discrete appearance
- Resolution 4DE simplified downfill and R18E also available



**Funktion-One Resolution 5  
Touring**

The Resolution 5 Touring enclosure is a high intensity three-way, mid-high loudspeaker used to create accurate point-source arrays. The unique and patented midrange Axhead loading device not only gives incredible efficiency and dispersion control, but also increases high frequency output from the 8" cone driver. This means that the crossover point to the compression driver can be raised to around 6kHz for dramatically reduced distortion compared to the compression driver based midrange so prevalent in the industry. Its highly controlled and focused dispersion enables precise tailoring of overall system coverage, simply through the geometry of the array. Unwanted room reflections are thereby substantially reduced, maintaining the enclosure's high intelligibility. The system's flexibility in application makes it suitable for any event size from 500 people to the largest festival, thereby maximising use of rental inventory. Its innovative and simple integrated flying system, combined with minimal size and weight, allow for easy and effective flying or ground stacking. The Resolution 5 is economic in terms of system cost, production budget and truck space. Above all, the accuracy and sonic quality it delivers are exceptional for all genres of music.

Features:

- Superior Point Source alternative to Line Array
- Fully horn loaded for high efficiency
- Funktion One designed Neodymium drivers
- Integrated inter-cabinet flying system
- Captive link lead in recessed cable pocket
- Identical size to Resolution 4 and 18
- Supplied with protective wheelboard
- Optional scrim for discrete appearance
- Simplified "Enclosure" and "Skeletal" versions available



**Funktion-One Resolution 4  
Downfill**

The Resolution 4D Downfill enclosure is designed to complete Resolution 5 flown arrays. It offers extensive vertical dispersion providing coverage right down to the first row of seats. Its unique tapered shape allows the rest of the cluster to be coupled closely together generating a coherent wave-front and adding a finishing touch to the spherical cluster's aesthetics. As with other Resolution Touring enclosures, all inter-cabinet flying hardware is included.

Features:

- Unique shape for close arraying
- Large vertical coverage
- Two-way active
- Horn loaded for high efficiency
- Funktion One designed Neodymium drivers
- Built-in flying hardware
- Optional scrim for discrete appearance



**Funktion-One Resolution 4  
Skeletal**

The Resolution 4S is a three-way mid-high skeletal loudspeaker, specifically designed to be cost effective by dispensing with the touring features (enclosure and flying equipment) in fixed installation applications. It offers uniform and controlled dispersion with sound quality equal to that of the enclosed versions. The Resolution 4S is suited to a wide range of applications including demanding club and theatre venues. Also available with a passive high frequency crossover, the R4S can be bi-amplified to minimise overall system cost. The mid-high horn section can be supplied rotated through 90° to facilitate horizontal use where ceiling height is restricted.

Features:

- Lightweight minimalist design
- Supplied in vertical or horizontal formats
- Funktion One designed drivers
- Suspension points provided
- Optional lightweight Neodymium magnets
- Optional passive HF crossover



**Funktion-One Resolution 4E**

The Resolution 4E is a great loudspeaker choice for medium scale events and installations offering exceptional sound quality. With simplified enclosure design without integrated flying hardware or captive lead found on the full touring version, the R4E represents great value for money. Typically used two wide for 90 degree overall dispersion it is perfect for use in ground stacks with F218 or F121 bass. Dedicated accessories also enable the R4E to be flown and arrayed in fixed installations



**Funktion-One Resolution 4  
Touring**

- Specifications

Driver	Operating Band	Sensitivity (1W at 1m)	Power (rms)*	Nominal Impedance
12"	114 - 445Hz	105dB	300W	8Ω
8"	445 - 5k77Hz	108dB	200W	16Ω
1"	5k55Hz - up	109dB	50W	16Ω

\*AES rated

Go to [crossover settings](#)

**Frequency Response  $\pm$  3dB:**

114Hz - 18kHz

**Weight:**

46 kg (101 lbs)

**Nominal Dispersion:**

50° Horizontal x 25° Vertical

**Connectors:**

EP6 panel and captive lead  
in cable recess



**Funktion-One Resolution 3 EH  
EVO**

The R3EH is the mid-high section of a Resolution 3 enclosed in a neat birch ply cabinet, offering high output and controlled directivity. It can be used in a wide range of applications which include providing additional coverage to a Resolution 3 system, as the high power mid-high section of a multi-way PA system (for example with DS15s and F221s) or in demanding speech based applications such as theatrical voice reinforcement.

Features:

- Funktion One designed drivers with Neodymium Magnets
- Passive option available
- M10 flying & mounting points
- R3SH EVO skeletal version available



The R3SH skeletal loudspeaker is the mid-high section of a Resolution 3 offering high output and controlled directivity. It can be used in a wide range of applications which include providing additional coverage to a Resolution 3 system, as the high power mid-high section of a multi-way PA system (for example with DS15s and F221s) or in demanding speech based applications such as theatrical voice reinforcement.

Features:

- Funktion One designed drivers with Neodymium Magnets
- Includes steel mounting yoke
- Optional scrim for discrete appearance
- Passive option available
- R3EH EVO version available in wooden enclosure

### **Funktion-One Resolution 3 SH EVO**



The R2SH skeletal loudspeaker is the mid-high section of a Resolution 2 producing high output for its compact size. Operating upwards from 250Hz it can either be used in conjunction with Funktion One bass enclosures such as the F118, F215 or BR118 as a main system in its own right, or used effectively as in-fill or delays in larger systems.

Features:

- Wide bandwidth with low distortion
- Compact and light weight
- Funktion One designed 8" loudspeaker
- Includes stainless steel mounting yoke
- 100V line and fire retardant versions available

### **Funktion-One Resolution 2 SH**



The R2S8 has been specifically developed for high quality speech reinforcement applications. It uses Funktion-One's advanced cone mid-range technology to produce clear and intelligible sound throughout the vocal band without the harshness usually associated with speech loudspeakers. The efficient wide-bandwidth 8" driver operates from 250Hz to 8kHz without the need for a separate compression driver. No corrective equalisation is required and the resulting sound feels perceptibly close to the listener so that messages and announcements sound natural rather than aggressive.

This R2S8 loudspeaker is highly durable and weather resistant and is supplied complete with a stainless steel yoke bracket and mesh

#### Features:

- Wide bandwidth with low distortion
- Compact and light weight
- Funktion One designed 8" loudspeaker
- Includes stainless steel mounting yoke
- Includes stainless steel mesh grill
- 100V line and fire retardant versions available

#### Funktion-One Resolution 2 S8

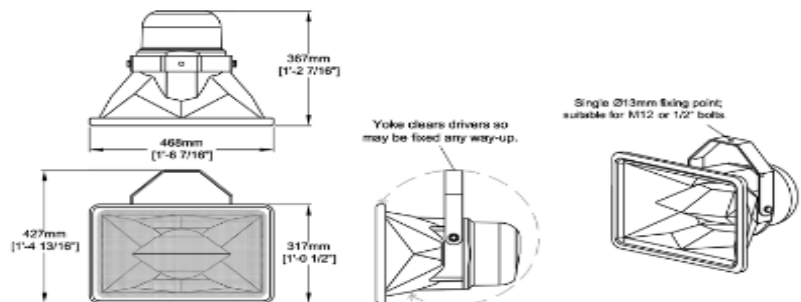



**Funktion-One Resolution 2**  
Horn-loaded compact full range  
loudspeaker enclosure

The Resolution 2 is an entirely horn-loaded, surprisingly compact, full range loudspeaker enclosure. The driver complement comprises a 15" for bass, an 8" for midrange and a 1" for high frequencies. Funktion One's waveguide and driver technology produces clear, involving and powerful sound. The R2's unique combination of size, high efficiency and sonic excellence make it ideally suited to a wide range of uses. This loudspeaker resolves the requirement for quality, response and level from a small source.

Resolution 2 systems can be supplemented with additional Funktion One bass including Infrabass, BR Series or F Series enclosures. A slightly larger horizontal version (R2U) is available for installation in venues with low ceiling heights.

Features:

- Full range, stand alone enclosure
- Fully horn loaded for high efficiency
- Three-way bi-amped (passive HF)
- Funktion One designed drivers
- Complete range of flying and mounting options
- Fitted with M10 flypoints
- Optional Wheelboard
- Optional scrim for discrete appearance
- R2S8, R2SH and R2EH mid/mid-high versions also available

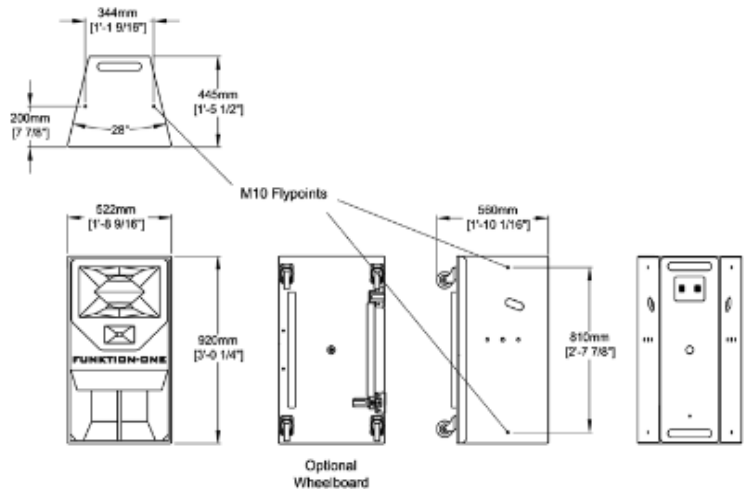

**Funktion-One Resolution 1.5TT**  
Wide dispersion for venues with low  
ceiling heights

The Resolution 1.5TT is a two-way enclosure specifically designed for mid sized venues with low ceiling heights. Combining twin 12" drivers as used in the Resolution 1 with the 90 degree dispersion 5" from the Resolution 1.5, it can be neatly installed tight against a ceiling providing good coverage due to the built-in downward angle of the devices. Its already strong bass response can be further extended with a wide range of Funktion One bass enclosures, particularly the BR and F series.

Features:

- Metalwork allows for close wall or ceiling mounting



**Funktion-One Resolution 1.5**  
**The Resolution 1's bigger brother**  
**with 18 inch bass and 90 degrees**  
**dispersion**

Building on the success of our innovative R1, the Resolution 1.5 is a 2-way loudspeaker enclosure with 90 degree dispersion, high-fidelity and good low frequency output for its size. Our unique ahead-loaded 5" cone loudspeaker is combined with a substantial 18" bass driver to present a highly capable two way enclosure. In common with the Resolution 1, the 5" eliminates the need for compression drivers with their inherent harshness and distortion. The 5" driver's ability to operate cleanly down to a low crossover point of 590 Hz allows the transition to the bass driver to be exceptionally smooth. Furthermore, our bass loading technology enables use of an 18" driver in an enclosure size where previously only a 15" loudspeaker could have been used. As usual with Funktion One there is no system EQ and the resulting sound is extremely involving. It is well suited to applications needing a single enclosure per side including theatres, entertainment venues and worship spaces.

**Features:**

- Very low distortion
- Wide dispersion
- Funktion One designed Neodymium drivers
- Integral 35mm pole mount
- Optional full grill for discrete appearance
- Optional Passive Crossover Module (PX1.5)

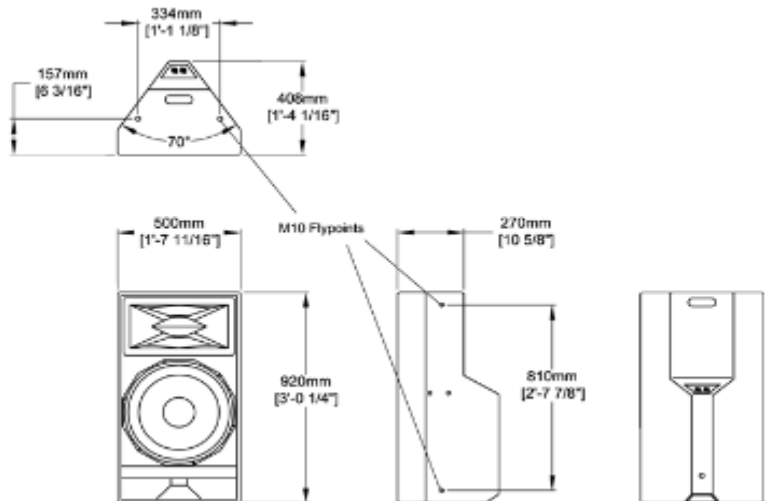



The Resolution 1 is a radical, 2-way loudspeaker enclosure, resulting from Tony Andrews' 40 years pioneering research and development of high efficiency cone mid-range. A unique Funktion-One 5" loudspeaker eliminates the need for compression drivers with their associated harshness and distortion. This device, when used in conjunction with the dedicated Axhead-loaded waveguide, smoothly reproduces both mid-range and high frequencies with exceptional coherency and detail. Further, this 5" device seamlessly connects with the 12" ported low frequency driver at 520Hz. This is in contrast to conventional 2-way systems where compromised compression drivers are stretched to (almost) meet equally stretched and indistinct 12" or 15" low frequency drivers at between 1 and 2kHz. The accuracy, projection and imaging detail of the R1 make it ideally suited to high intelligibility applications including theatrical use.

The enclosure shape has a rear recess that can be fitted with the optional PX1 passive crossover module. The waveguide can be rotated for use in either vertical or horizontal formats.



#### Features:

- Very low distortion
- Funktion One designed Neodymium drivers
- Rotatable mid-high waveguide for horizontal use
- Integral 35mm pole mount
- Optional full grill for discrete appearance
- Optional Passive Crossover Module (PX1)
- Complete range of flying and mounting options

**Funktion-One Resolution 1  
Radical & accurate loudspeaker  
enclosure with no compression driver**



**Funktion-One AX88**  
**Passive Mid-High for a wide range of applications**

The AX88 is an extremely useful 2 way passive mid-high loudspeaker with a 60° by 55° dispersion. It provides a cost effective, high quality solution for many diverse and demanding audio applications including Arena, Stadia, Theatrical and Entertainment installations. Its high efficiency, wide frequency range and low distortion delivers particularly clear and intelligible speech. AX88s are often selected for acoustically challenging environments such as Ice Arenas and other large hard surfaced venues where their controlled dispersion keeps reflections to a minimum. With the addition of Funktion One bass products like the F215, F118 or F121; AX88s can also be used as a highly effective music system.

Existing clients include Kojice Steel Arena in Slovakia, Ipswich Football Club in the UK and the renowned Cielo Club in New York.

Features:

- Controlled and even dispersion
- Funktion One designed drivers
- Includes stainless steel mounting yoke
- Weather-resistant version available
- 100V line and fire retardant versions available
- Optional scrim for discrete appearance
- Additional metalwork available to fly coherent clusters
- AX88E version available in wooden enclosure



**Funktion-One F88**  
**Wide Dispersion Loudspeaker**

The F88 comprises two Funktion One designed wide bandwidth 8" loudspeakers with a passive slot tweeter delivering frequencies above 6kHz. Particular attention has been paid to the arrangement of the drive units to optimise coherency. The F88's 110° dispersion and 99dB sensitivity from 70Hz to 18kHz allow it to be used in numerous applications including under-balcony, theatre, bar/club, cinema surround and AV. The F88 delivers full-range sound in its own right and can be given more authority with the addition of Funktion-One bass enclosures including MB212 and F or BR118.

Features:

- Wide dispersion
- Wide bandwidth
- Funktion One designed 8" drivers
- Choice of grill types

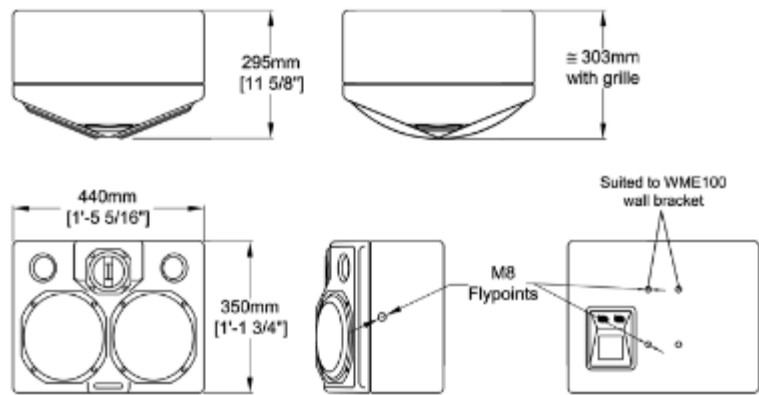

**Funktion-One F1201**  
**Compact enclosure with high output**

Funktion One have meticulously applied their purist design approach to the ubiquitous 12" and horn loaded 1" configuration, steering clear of any additional processing or passive network EQ and so preserving coherence of phase and transient response. The consequences are realism, detail and liveliness. The F1201 is a naturally balanced compact product with high output, even response and well defined frequencies.

Features:

- Compact enclosure with high output
- Rotatable HF horn with 90° x 40° coverage pattern
- 12" and 1" drivers optimised to Funktion One specification
- Excellent sensitivity
- High passive crossover point to HF driver for low distortion
- M10 mounting and attachment points
- Integral pole mount



**Funktion-One F101**  
**Funktion One sound quality from a**  
**compact enclosure**

The F101 loudspeaker brings Funktion One's unique sound quality and purity of design to a wider audience than ever before, offering a fresh choice to those searching for sonic involvement from a small source.

The F101 delivers excellent definition and full bodied vocal intelligibility. In common with our larger scale systems, this loudspeaker also provides high imaging detail and clarity. Furthermore, with Funktion One's exceptional enclosure tuning and driver optimisation, no processor or system equalisation is required, maximising the fidelity, performance, natural simplicity and cost effectiveness of this product. Its sensitivity of 101dB for 1 Watt at 1 Metre is unprecedented for this class of loudspeaker. Out of operating band low frequency protection is incorporated.

The F101 is ideal for many applications including studio reference monitoring, AV presentations and theatre use. It is the product of choice for many bar and restaurant installs. In 2010, the F101 was awarded the DJ Magazine Tech Award for Studio Monitor of the Year.

The F101 forms a potent system when complemented with Funktion One bass enclosures including the MB210LP, MB212 and the smaller BR & F series enclosures.

Features:

- Compact enclosure with high output
- Wide dispersion
- 10" and 1" drivers optimised to Funktion One specification.
- Excellent Sensitivity
- High passive crossover point to HF driver for low distortion
- Choice of Speakon or Installation connectors
- M8 mounting and attachment points
- Curved powder-coated mild steel grill
- Integral pole mount



**Funktion-One F81**  
Funktion One sound quality from a small enclosure

The F81 loudspeaker delivers great sound and performance from a compact enclosure. In common with the F101, the smaller F81 also features excellent definition and vocal intelligibility. It makes a great choice for use in distributed systems and ancillary zones as well as allowing home studios and smaller venues to benefit from the exceptional clarity and purity of Funktion One sound.

If additional bass is required, the F81s are ideally complemented with our MB112, MB210LP or smaller BR enclosures.

Features:

- Compact enclosure with high output
- Wide dispersion
- 8" and 1" drivers optimised to Funktion One specification.
- Excellent sensitivity
- High passive crossover point to HF driver for low distortion
- Choice of Speakon or Installation connectors
- M6 mounting and attachment points
- Curved powder-coated mild steel grill



**Funktion-One F55**  
Ultra Compact Loudspeaker

The F55 ultra compact loudspeaker is the perfect choice for applications requiring wide dispersion near field coverage including bars, theatre front fill, under balcony and domestic use. This high sensitivity enclosure delivers good vocal intelligibility with excellent clarity and imaging detail; attributes not usually present in compact loudspeakers. Dual 5" drivers manufactured to Funktion One specification have been carefully optimised with the enclosure tuning for use without processing or system equalisation for natural simplicity and high fidelity. In common with the F81 and F101, out of operating band low frequency protection is incorporated. If additional bass reinforcement is required our smaller bass products including the MB112, MB210LP and BR115 enclosures make the perfect complement.

Features:

- Ultra-compact enclosure
- Wide and even dispersion
- 5" drivers optimised to Funktion One specification
- Excellent Sensitivity
- No compression driver
- Choice of Speakon or Installation connectors
- M6 mounting and attachment points
- Curved powder-coated mild steel grill

